

An Innovative Approach for the Management of Cross-Coupling Interference in Street Lighting Networks

Giovanni Pau^{1*}, Mario Collotta¹, Salvatore Tirrito¹, and Riccardo Caponetto²

¹*Kore University of Enna, Enna, Italy*

{giovanni.pau,mario.collotta,salvatore.tirrito}@unikore.it

²*University of Catania, Catania, Italy*

riccardo.caponetto@dieei.unict.it

Abstract

Power Line Communications (PLCs) are used for measuring various metrics, that can give signs about the health of the power grid equipment and for maintenance actions. These measurements may include the values of voltage, current, temperature and pressure of the power grid equipment. As it is known, the communication may also depend on the structure of the transmission medium, i.e. the parasitic capacitances and inductances and the cross-coupling interference between phases. This paper introduces an innovative solution with the aim to reduce the impact of noise and interferences in street light systems based on PLCs for telemetry. The proposed solution can cope with several problems, such as the capacitive and the inductive coupling among phases and attenuation. The goal of the solution introduced in this work is to make the communication, among master and slave nodes, reliable and immune to noise. The proposed solution also allows a significant reduction of power consumption with a consequent lowering of CO_2 emissions, acting on the automatically dimming and switching off the street lamps.

Keywords: Street Lighting System, Power Line Communication, Power Consumption Reduction, Remote Control.

1 Introduction

Street lighting is a fundamental part of the city's infrastructure since it plays a vital role both in road safety and city attraction. Traditional streets are lighted by High-Pressure Sodium (HPS) lamps, without controllers that, for instance, could reduce the luminous flux after a planned time. This approach would facilitate the development of distributed controllers [1] that would bring several advantages [2], such as the use of a management system able to monitor the entire infrastructure remotely (using appropriate commands) and to detect diagnostic feedback, i.e. the state of the lamp. The traditional approaches, on the contrary, do not implement the communication among the lights (i.e. slave nodes) and a central controller (i.e. the master node) [3]. In fact, they employ just a photodiode and/or a timer that gives useful information locally on each controller of the lamp to reduce the light intensity.

In the last few years, to decrease the power consumption [4, 5, 6], the environmental pollution [7, 8] and the maintenance costs [9, 10], the use of a centralized control that aims to an automatic reduction of the luminous flux on roads has been increased substantially. To this end, several works have been introduced in the literature [11, 12, 13] developing the communication to a master node (i.e. the network controller) through different network protocols, such as:

- RS485 [14]: it has a strong noise immunity although has a disadvantage related to the costs of wiring;

Journal of Wireless Mobile Networks, Ubiquitous Computing, and Dependable Applications (JoWUA), 8:2 (June 2017), pp. 44-63

*Corresponding author: Faculty of Engineering and Architecture, Kore University of Enna, Cittadella Universitaria, 94100 Enna, Italy, Tel: +39-0935-536494

- ZigBee [15] or Wi-Fi [16]: these protocols are based on IEEE 802.15.4 and IEEE 802.11 in the physical and the MAC layers respectively. Moreover, these protocols grant a larger autonomy from vendors and the interoperability among products. Nevertheless, they are also marked by some problems related to co-channel interference, multipath fading, and attenuation of transmitted signal in areas with natural obstacles, in addition to the hidden network problem [17, 18];
- Power Line Communication (PLC) [19]: it is a technology that requires no additional wires to connect beyond the electric grid for data transmission, allowing the reduction of wiring costs. Moreover, PLC has also the advantage of being able to keep the connection in different situations, such as underground or in the presence of walls and curves. The communication channel, owned by the operator or the utility, avoids the occurrence of errors due to a shared band. This problem is well known in an environment that uses a wireless technology. Recently, the scientific investigation has highlighted the problems associated with centralized bright stream management over PLC. As a consequence, the issues related to noise immunization limit have been proved. On the contrary, several advantages have also been highlighted, mainly related to the ease of installation since it does not require extra wires [20].

Despite the advantages that have led the PLC-based solutions to grow not only for road monitoring applications but also in home [21] and industrial [22] automation, several factors have to be analyzed carefully. Among them, those associated with the constraint imposed by the topology of the network (i.e. the master/slave communication) [23] in which, for instance, the data exchange can occur only among master and slaves; the communication among slaves is not possible. Therefore, if the master collapses, all network communication are suspended. As highlighted in [24], this is a contextualized problem, such as in industrial scenarios, so it is not a real issue in networks for road lighting management. In fact, the data interchange among individual lamps is not necessary because the lamp should only handle the commands received from the central controller and transmit information about its status. Besides, this difficulty is not difficult to solve. For instance, as shown in [25], the lamp will work independently if it is not probed for a certain time. In this case, the lamp remains with 100% flux or achieves default flux attenuation curves (in time frames). As a result, this mechanism occurs in the absence of communication with the master.

Regarding the Medium Access Control (MAC), which is closely linked to the interference in communication protocols, in PLC, as shown in [19], different techniques can be implemented, such as fixed access, changing protocols with contention, reservation protocols and arbitration protocols (token, polling). Normally, power grids are based on a bus or a tree structure where the root is the master of the network (terminal serving), and the communication can also occur among individual nodes. In this research field, two protocols have been introduced in the literature, that are polling and Aloha. The latter has the biggest disadvantage of having a low throughput with increasing network load. On the contrary, the polling can manage massive traffic and can afford the quality of service guarantees. Nevertheless, the polling can be ineffective under highly or light asymmetric traffic models, or when polling lists must continually be updated due to the adding or removing of network terminals. The Carrier Sense Multiple Access (CSMA) has also been suggested for overload discovery. CSMA is considerably effective under average traffic loads. The main benefit of the CSMA is its low cost regarding the implementation. The Collision Detection (CSMA/CD) version could improve the performance of CSMA. However, on power line networks the notable difference of the received signal and the noise levels make the collision detection complicated and tricky. An option to collision detection that can be simply applied in PLC situations is the Collision Avoidance (CSMA/CA), a method that is based on casual backoffs to diminish the collision possibility further. In a structure like urban street, it is possible that the polling associated with a single master request can be a well suitable protocol, taking into account that street lighting events are very few and very slow.

In this paper, an architecture that enables the creation of a Master/Slave communication network, among a central controller and the streetlights, is introduced. The proposed architecture, based on PLC, advances state of the art regarding:

- analysis and management of networking;
- management and monitoring of the lamps coping with noise problems associated to the cross-coupling between attenuation and phases due to the distance.

The solution introduced in this work extends that presented in [25] by introducing remarkable improvements and differences. First, new embedded devices (master/slave) are designed and created ad-hoc to be used in real experimental scenarios. The application of these devices allows achieving excellent results concerning the cross-coupling interference reduction, which is the main goal of this paper. Besides, thanks to the new capabilities offered by these ad-hoc designed devices, this work addresses new performance evaluations regarding the routing and, mainly, the power consumption. In fact, compared to the testbed implemented in [25], in this paper the traditional 200W HPS lamps are replaced with those 80W LEDs to measure the power consumption.

This paper is organized as follows. Section 2 analyzes some problems and open challenges shown in several literature works; moreover, the motivation and the scope of this paper are discussed. The proposed system model is introduced in Section 3, also showing the related network architecture used to design and to validate the proposed approach. Section 4 presents the proposed improvement for the noise effect due cross-coupling, while Section 5 assesses the performance obtained in real scenario implemented in a little city at the center of Sicily - Italy. Finally, Section 6 concludes the paper.

2 Problems and open challenges

Problems and open challenges have been analyzed in several literature works. In [26], the authors introduce a system for street lighting management through PLC. Although particular problems of low-level transmission among lamps and the master node are not addressed, the analysis carried out by the authors is useful to draw some conclusions. Power Line Communication outlines a very open research area, especially in those topics focused on improving the data transmission performance. In general, the transmission by using the PLC technology is affected by several factors, such as, for instance, the attenuation induced by the cable, that increases with the bus length and the used frequency, and the multi-path caused by “Branch” and “unmatched line ends”. It is useful to note that this paper is focused on these features.

The application of the OFDM (Orthogonal Frequency-Division Multiplexing), as a communication technique, is proposed in [27]. According to the authors, OFDM counteracts well with the problem of the frequency fade on the channel, thanks to the division of the usable bandwidth into N sub-bands with size equal to F_c (sampling rate) obtained from the ratio between B (bandwidth) and N . Consequently, a stream of N symbols is disposed on N carrier frequencies and transferred in parallel. The significant advantage of the OFDM solution in “frequency selective fading channel”, as the power line, is the simplistic equalization in addressing issues emerging from critical channel status and multi-path.

The authors of [28] suggest the application of an adaptive filter in every receiver/transmitter, on any duplex channel, with the aim to reduce the noise associated with switching transients. Moreover, another goal is to address the problem of cross-coupling which produces the lowering of signal to noise ratio. In the solution introduced by the authors, the transmission channel is adjusted through adaptive filters for distortion compensation. All channels are linked to the power line employing a hybrid line. The latter is composed of a receiver/driver device including an echo controller and a bridge circuit that allows the data exchange by reducing the echo effect across the same band of frequency. The hybrid line

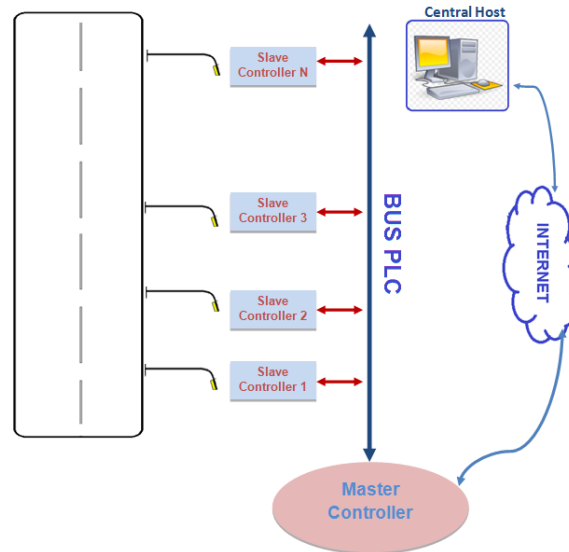

Figure 1: Street light system administration.

(drivers/receiver) and the adaptive filter improve the signal to noise ratio of every duplex channel, giving two duplex channels over the three power lines, also extending the PLC system bandwidth.

Finally, in [29], the use of an electronic circuit for decoupling, capable of addressing the issue of the “signal interference coupling”, is introduced. The authors suggest the development of an innovative structure for the monitoring and the remote control of a street lighting system, accomplished through a master board into the cabinet and slave one in every street lamp. The data exchange among master and slave nodes happens through the power line, while between the central controller and the master through GPRS-GSM.

2.1 Motivation and scope of the paper

Some actions must be implemented to overcome the limitations of PLC and to obtain a high baud rate and a noise-free communication. If in not extensive networks (i.e. home automation scenarios), the problems could be restricted and limited, a road leads to a notable degradation of the signal quality. In fact, it can be distinguished by considerable bifurcations, and the signal can also be degraded due to significant reflection points and the cross-coupling effect, between both pairs of phases of the three phase cable and the common neutral conductor. Therefore, to maintain the integrity of the signal in a scenario like a road, it is useful not to exceed a maximum length of about approximately 400 meters between a receiver and a transmitter and also a determined maximum frequency, from 50 to 140 kHz. In fact, the attenuation increases both with distance and with frequency. Nevertheless, the design of a PLC network that takes into account these limitations is not sufficient to reduce/eliminate cross-coupling interference.

In this paper, a solution depicted schematically in Figure 1, able to substantially reduce the problem of inductive and capacitive coupling among the phases, managing and combining individual identifiers (IDs) associated to each slave (lamp of the road network) dynamically, is presented. In this way, each slave can process only messages addressed to itself. Moreover, the proposed approach offers a compelling resolution also for the automatic addition or removal of nodes (slaves) in the network. The proposed approach, described in detail in the following subsections, can dynamically provide, at the start-up, the identifier to the components of the communication network, making sure that all slaves can interact with the master. For this reason, it is helpful to study the use of polling in streetlights, for

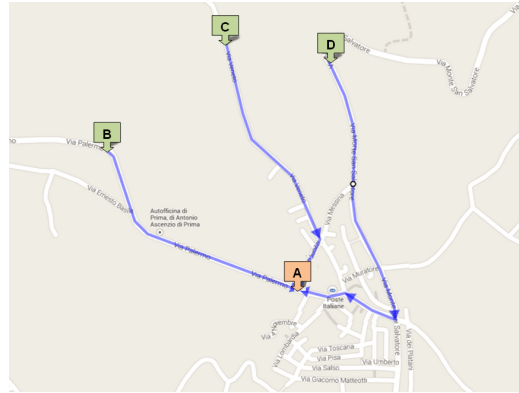

Figure 2: Castellana town map.

instance, to monitor the electric current drawn by each slave; if this proves different from what was expected, an alarm message can be sent to the central manager. As a consequence, at periodic intervals, the master will receive the setting of commands that have to be delivered to every slave. These commands contain the luminous percentage to be completed within a time span. Finally, the proposed approach also enables to recognize the best pathway between each slave and the master, making sure that all slaves can additionally behave as a repeater.

3 The proposed system model

A quite a large number of lamps, divided into areas, lines, and phases normally define a street lighting system. The scenario considered in this paper (Figure 2) has been implemented, using embedded devices ad-hoc designed for the scope of this work, in Castellana Sicula. It is a little town in Sicily - Italy. The proposed solution is based on the system model depicted in Figure 3. In the solution introduced in this work, all lamps are provided with an ID with the aim to distinguish the proper lines, the different regions, and the phases to which they are attached. The master node (depicted in Figure 3 as Master Controller), implements the Power Line Transceivers and several connections modules, such as that of GPRS, with the aim to transfer data to a host application using the TCP/IP. Moreover, it manages the data exchanged with slaves (i.e. Slave Controller in Figure 1).

Through this network architecture, it is possible:

- to send ON/OFF commands to turn off and turn on the lamps at certain times and in the maintenance phases;
- to dim all lamps to decrease the light flow of at some time and/or when vehicles or pedestrians are not detected;
- to check the status of each lamp, measuring the current consumption, useful for the maintenance;
- to collect data related to the surrounding environment, such as humidity, wind speed and direction, lighting, temperature, and so on.

The system depicted in Figure 3 is characterized by three main modules:

- Central Host: installed on the PC of the road network administrator, consisting of a client and a server side;

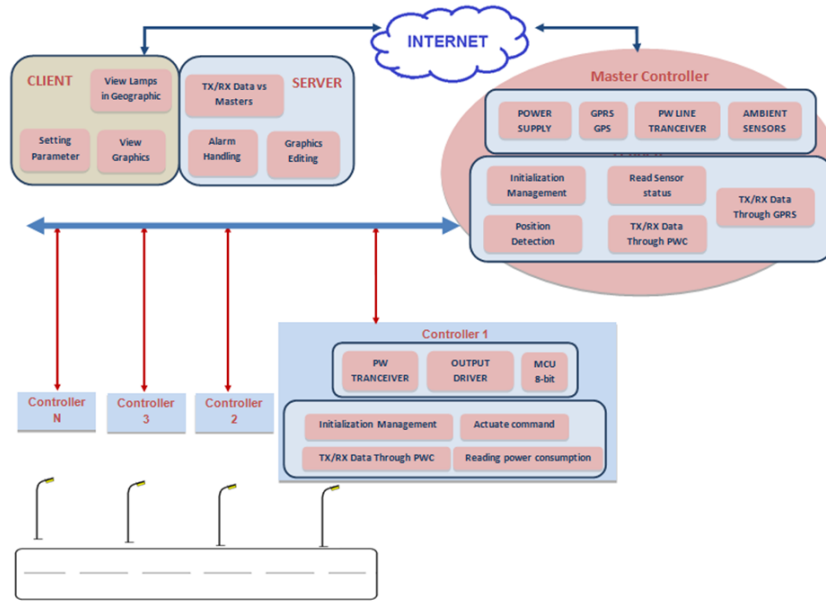

Figure 3: Details of Street light system.

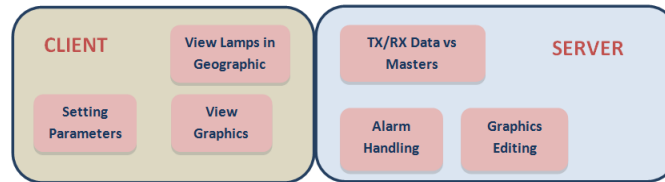

Figure 4: Central Host architecture.

- Master Controller: implemented on the cabinet in the street;
- Slave Controller: included on every lamppost.

In the following subsections, the design and the implementation details of each of these components are described. It is necessary to note that these devices have been specifically designed and ad-hoc created; subsequently, they have been implemented in the town of Castellana Sicula to made a real test-bed scenario.

3.1 Central host

The central host is characterized by the architecture shown in Figure 4, composed of two sides: a server and a client. The first can perform the data processing, while the second is useful for the setting of parameters. The Server, developed in Java programming language, consists of a single process that collects data through the various opened sockets with each Master Node on the network (TX/RX Data to Master controllers). Moreover, it checks the integrity of the messages (CRC calculation and checksum) and sends the data for the flow percentage that must implement each lamp; in addition to doing the ping-alive with concentrators in the cabinet.

In the entire city network, it is possible to have multiple Master nodes. The opening of many N sockets as many as the number of Master nodes, on different ports, can avoid collisions among data

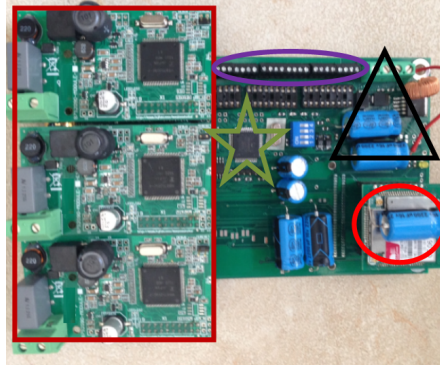

Figure 5: Master board layout.

packets. In fact, if the value of N is not sufficiently large, the data may interbreed and then discarded due to the control features of CRC and checksum, thereby leading to an excessive number of data frames lost. For this reason, the approach introduced in this paper reduces this problem because it opens a number N of sockets as many as the number of Master nodes. If an alert message is obtained from the Master node, for instance, in the case of a damaged lamp, or in the case when the slave is no longer active, then the server enables the function of Alarm Handling (Figure 4). As a consequence, the server updates the database so that the concerned Clients, whether online, can view the status of the updated street light; their web page will be refreshed at regular intervals (10 seconds), and alerts are sent through e-mails to contacts included in the notification area.

The Graphics Editing, shown in Figure 4, collects data to display, on the client side, the information received from sensors in the infrastructure. The client, developed in Oracle XE (the free version of the most popular commercial Relational Database Management System), allows the management of telemetry in street lights and it can perform the following steps:

- the addition or removal of a lamp;
- the setting of the luminous flux for time slots via tables;
- the switching on/off of lamps, for instance, during maintenance of a single pole or a whole line;
- the displaying a topographical map of the master and slaves attached to it and the plotting of charts related to the fuel consumption, the emissions of CO_2 , the number of cars that occurred near the detection sensor, the level of illumination in lux, and so on.

The client side, depicted on the left in Figure 4, is only a web application, so the administrators that have the needed credentials can have access to it from anywhere, at any time and with any device. Therefore, the maintainer, when a lamp needs to be replaced or checked (even remotely), can disable, enable and control each lamp post in real-time with his device.

3.2 Master Controller

The Master Controller, shown in Figure 5, manages the three phases of the network to which it is connected and communicates directly with slave nodes and the central host. Moreover, it can gather data from the surrounding environment, such as temperature, humidity, wind direction and speed, atmospheric pressure, and so on. The Master Controller has been implemented taking into account both its firmware parts and the hardware ones. The Master board, from the hardware point of view, is divided into four sections (Figure 6):



Figure 6: Master controller hardware side.

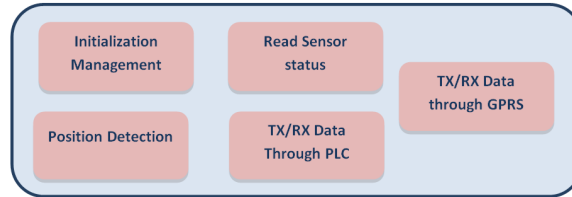

Figure 7: Master controller software side.

- power supply circuit for the microcontroller, having a commercial power source AC/DC 12V high PFC to avoid the possible occurrence of electromagnetic interference (inside the black triangle shown in Figure 5);
- detection of position and data sending using SIMCOM SIM908 module, i.e. Quad-Band GSM/GPRS module which combines GPS technology for satellite navigation (red circle area shown in Figure 5);
- three power line transceivers ADD1010 with architecture-based processor 8051, one for each phase, able to send and receive data on the bus (red rectangle area shown on the left in Figure 5);
- environmental sensors, connectable to the micro PIC24F (green star area shown in Figure 5 through the terminals highlighted by the purple oval), such as:
 - photodiode, for luminance detecting;
 - PIR/ultrasonic sensors in order to detect the traffic intensity;
 - wind speed sensor, in order to detect the speed of the wind;
 - weather vane sensor, for detecting the direction of the wind;
 - humidity sensor;
 - temperature sensor.

The Master, from the software point of view, is characterized by different modules, shown in Figure 7:

- initialization routine, with the aim to map the entire Master/Slave network, explained in detail in Section 4;
- routine useful to acquire the location of the SIMCOM module (latitude and longitude), using standard AT command offered by the hardware manufacturer, sent via serial port. GPS is set to send, every 2 minutes, latitude, longitude, time and date;
- routine useful to read from sensors, through AD converter or using serial port;

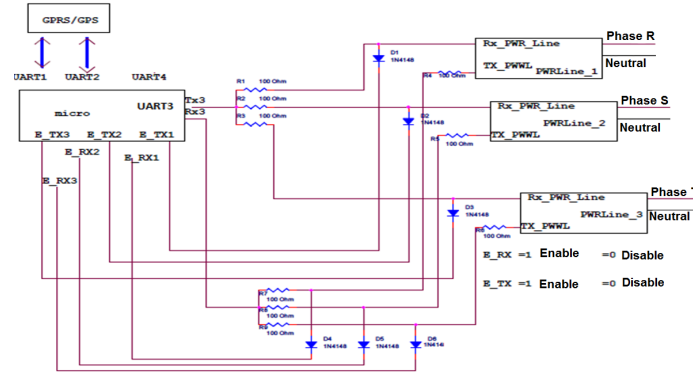

Figure 8: PLC transceiver serial communication scheme.



Figure 9: Slave controller layout.

- routine with the aim to engage communication with the slaves on the Power Line Channel through the UART. Since the communication must take place in the three phases, it would take three UART to manage the Power Line Channel. It has been chosen to employ only one serial port for managing the communication through the circuit diagram shown in Figure 8 to maximize resource utilization and to use the Micro PIC24F on the board having only four UART. Three diodes are shown in Figure 8, with the cathode connected to the output of the microcontroller. Therefore, during transmission, if the communication to one of the three phases takes place, the cathode of the diode, connected to the other two channels, is sent to a logic 0, so it is as if the other two lines were shorted to GND. Similarly, this occurs during the reception (side PIC24F); this is achievable since the microcontroller is always conscious of the slave node that it is going to answer because, in the case of broadcasting transmission, there is no echo from the slaves, while a query to a specific slave corresponds to a reply. If this does not happen within a timeout equal to 100ms, the Master will retry the query three more times; in case no response is still received, then the slave will be marked as lost;
- routine useful to engage the communication with the central host via GPRS using the UDP protocol [30] and standard AT commands offered by the manufacturer [31].

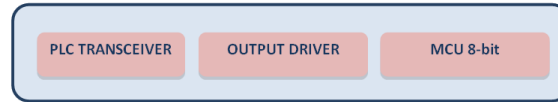

Figure 10: Slave controller hardware side.

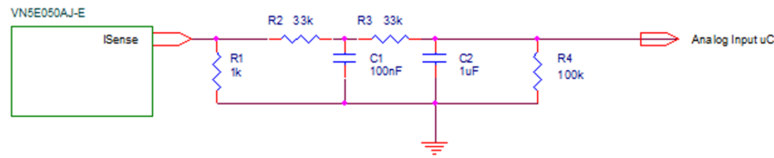

Figure 11: Isense circuit.

3.3 Slave Controller

The Slave Controller (depicted in Figure 9) is implemented in every street lamp and is used to perform the instructions received from the master PLC controller, making an analysis on the state of the lamp. It is characterized by three hardware modules (depicted in Figure 10):

- power line transceivers, which have the aim to communicate with the network administrator;
- output drivers, able to drive the load (lamp LED) in pulse-width modulation (PWM) or with ON/OFF controls and outputting a diagnostic feedback;
- an 8-bit microcontroller able to handle the output driver.

The PLC transceiver is similar to that of the master node. It is composed by an 8051 processor architecture, while the power driver VN5E050AJ-E is a single channel high surface driver with analog current sense. This power driver is often used in the automotive field, is capable of driving a load with absorption up to 20A and is able of providing an output I_{sense} about 2000 times lower than the current drawn by the lamp. Various solutions have been presented with the main goal to make the diagnosis of the load. For instance, the study carried out in [29] involves the use of a current transducer (LTS 25-NP), which provides an output voltage proportional to the measured current. However, to convey this information to the microprocessor, it is necessary to use an electronic circuit to deal with the operational amplifiers for adapting the signal to the input dynamic range of the microprocessor. On the contrary, adopting a solution based on VN5E050AJ-E, with the same electronic component, it is possible to drive the load and measure the absorbed electric current. It is sufficient a R_{sense} and a second RC filter so that if PWM controls the load, a constant value is still provided to the microcontroller to perform this operation. The designed circuit, taken into account in this work, is depicted in Figure 11.

The presence of R4 in Figure 11 is useful to speed up the discharge time of the capacitor in the OFF command of the lamp. Therefore, assuming a maximum electric current absorbed by the load equal to

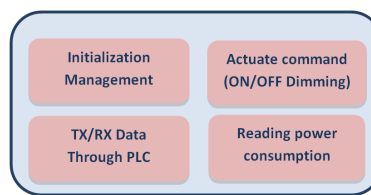

Figure 12: Slave controller software side.

10A, the I_{sense} will be approximately 5mA, on R1 will fall 5V, while the AD converter of the micro will have an input voltage equal to:

$$V_{ADC} = \frac{R_4}{R_4 + R_3 + R_2} V_{R1} = 3,01V \quad (1)$$

In this way, the 8-bit MCU will send the corresponding digitized value to the power transceivers via serial, to be delivered to the Master Controller and finally processed by the Central Host. The Firmware blocks in the Slave Controller, shown in Figure 12, are:

- Initialization Management, able to respond to the Master in the initialization phase of the network;
- Tx/Rx Data, useful for communication in PLC, through the serial port;
- Actuate Command with the aim to pilot the power drivers. When the command of implementation through PLC are received, they are interpreted by setting the input of the driver power to a fixed logic value (0=OFF, 1=ON) or modulating in PWM to implement the wanted Dimming;
- Reading Power Consumption, useful to make the diagnosis on the lamp through the circuit described previously (Figure 11).

4 An effective improvement to noise effect

As mentioned previously, the biggest problem in a network such as that of road lighting is represented by the cross coupling between the three phases. This issue can lead to errors (noise effect), and then the slave cannot implement the received commands. In the case in which the master node begins a communication to a lamppost on one of the three phases, the command that it sends is also received by the other slave nodes, generating conflicts and unexpected answers. Capacitive and inductive coupling raises this issue (either through the neutral conductor that on the conductors of the other two phases),

Consequently, it is crucial to associate different identifiers to all controllers (slave node) on each street lamp. A different identifier (ID) must be written in the EEPROM/Flash of the controller, during the programming phase, to realize this characteristic. Nevertheless, this mechanism involves numerous restrictions to the installer, as it is bound to put every lamp in the proper place. Moreover, when a lamp must be replaced, i.e. in the event of failure, it is required to go back to the ID of the slave node to substitute the controller with another one with the corresponding ID. It is clear that the main limit of this solution falls in the for power line failure, as it expects a preliminary configuration work to the laying of the same power line transceiver. To solve this issue, an algorithm is introduced in this works through which, at a start-up time, by transmitting a particular command, a phase is actuated at a time, detaching the others two. In this way, the master node can probe in broadcasting and receive a reply from each slave node, assigning a different identifier (i.e. an alias) to all lamps with its MAC address (unique code on 6 bytes configured in programming phase).

Thus, at power up, each slave starts transmitting, one at a time, its MAC address, opening a time window obtained by the last digits of the MAC different code spacing of 50 ms each transmission, to avoid that possible conflicts arise. A reference diagram is depicted in Figure 13. It is shown the case in which there are three slave with MAC address equal to 0x000000000001, 0x000000000010, 0x000000000011. In this way, considering the time instant $T = t_0$, the time when the phase goes on, after 50 ms the Slave 1 transmits having the MAC address equal to 1. After 100ms there is the transmission of the Slave 2, having the MAC address equal to 2; subsequently, 150 ms after the Slave 3, having MAC address equal to 3, transmits.

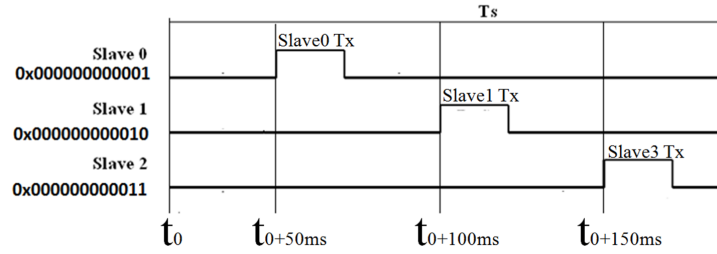

Figure 13: Power up Slave Transmission.

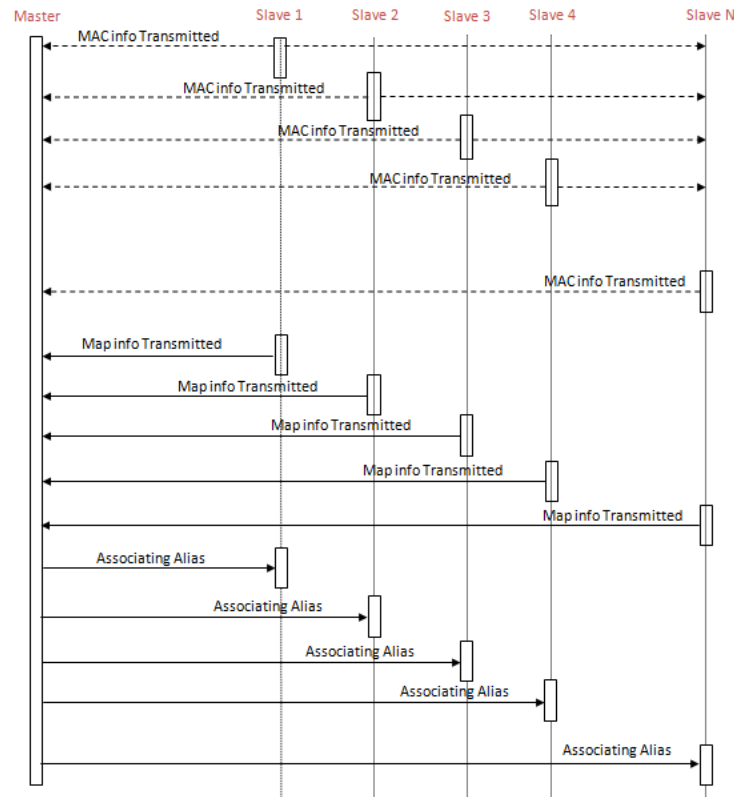

Figure 14: UML network initialization scheme.

Considering that it is only one node at a time to undertake the communication, the others, at data reception, store the unique identifier of the sender. So, every node is conscious of the slaves next to it, and this data is transmitted afterward straight to the master node or by the slave controllers. In this way, the network manager (i.e. the master controller) has the complete plan of all slaves. As a consequence, when the communication with a distinct node is required, the network manager is aware of the path to reach it.

After the definition of the whole plan, a different numeric alias of 6 bytes for every device is allocated. Considering the UML chart presented in Figure 14, the dotted lines represent the broadcast information transmitted by each slave controller. It is clear that all the nodes will not receive it because of the line attenuation. On the contrary, the continuous lines, shown in Figure 14, denote the direct or indirect message transmitted from Master to slave and vice-versa. In detail:

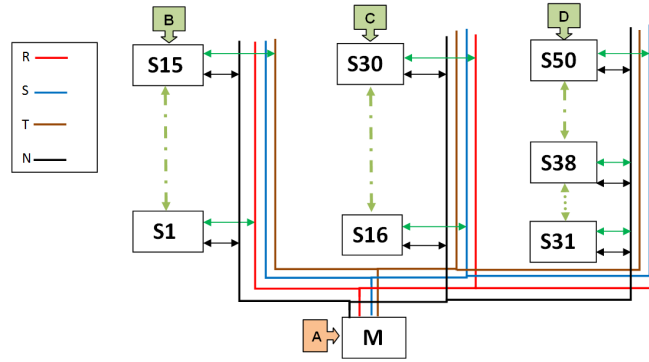

Figure 15: Power Line infrastructure.

- the opening sequence represents the slave controller transmitting in broadcast its own MAC address;
- the second sequence refers to each slave controller transmitting a frame containing a list of slave nodes close to it;
- the last sequence describes the transmission of an unicast message from Master to each Slave controller to associate an alias.

5 Performance evaluation

The experimental measures have been carried out in Castellana Sicula, a small town in the province of Palermo, Sicily - Italy. On-field tests have led to very promising results. The network structure, shown in Figure 2, implemented in Castellana, is composed of 50 street lights diffused over 3 lines. In the power line infrastructure, the maximum range between the Master controller and the lamp is about 650 meters (Slave 050). It is summarized in Figure 15. The lines are organized in the following way:

- line 1 (from tag *A* to tag *B*) has a length of 450 meters, and it is constituted by 15 street lamps;
- line 2 (from tag *A* to tag *C*) has a length of 450 meters, and it is constituted by 15 street lamps;
- line 3 (from tag *A* to tag *C*) has a length of 650 meters, and it is constituted by 20 street lamps.

Numerous tests have been carried out adopting a digital oscilloscope attached to the monitored devices, i.e. embedded systems within the cabinet (Master node) and street lamps (Slave nodes). Figure 16 shows a standard query from the Master (section labeled as *A*) and the response of a Slave (section labeled as *B*). The plot refers to the transmitted signal on the main grid modulated in FSK. The measurement has been carried out at the output of an isolation transformer. The section of Figure 16 labeled as *A* shows the command *AT * WRFLU001998700000001* sent from the Master to the Slave 001. It corresponds to the implementation of the luminous flux at 70%. The transmitted package, depicted in Figure 17, is structured as follows:

- Command Name: *AT * WRFLU*;
- Recipient: 001 (first slave ID);
- Sender: 998 (ID Master Controller);

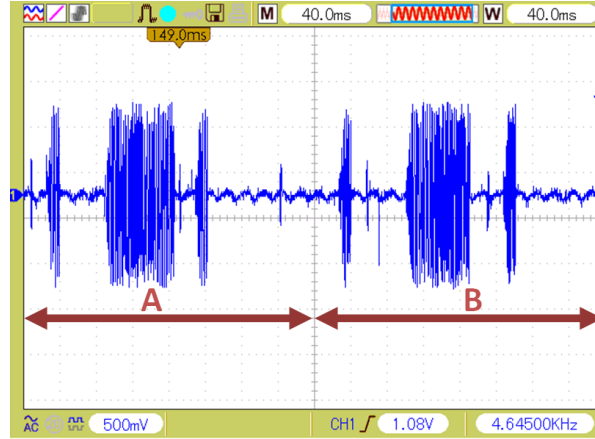

Figure 16: Typical Master Request Slave response FSK data transmission.

Command Name	ID Receiver	ID Sender	Flux to implement	Write Flash Command
--------------	-------------	-----------	-------------------	---------------------

Figure 17: Typical Data frame.

- Flux to implement: luminous flux for 4 channels available. In particular, it will contain 4 parameters, one for each channel [70] – [00] – [00] – [00] (70% output channel 1, 0% other outputs). The lamp with this ID, specified in the recipient, is connected to the first channel, then it will light with a luminous flux equal to 70%;
- Write Flash command: it specifies whether or not to write the received command in Flash (1 means TRUE while 0 FALSE).

The Slave replies with the same package shown in Figure 17, by sending *AT *RDFLU998001700000001*. The fields of the packet contain the following values:

- Name command: *AT *RDFLU*;
- Recipient ID: 998;
- Sender ID: 001;
- Flux to Implement: flow rates implemented on each channel (first channel 70%, 0% other channels);
- Write Flash command: the correct writing of the received packet in Flash.

The event of the cross-coupling interference is depicted in Figure 18. The previous information, transmitted by Master node to Slave 001, working on the first phase, arrives at another node that is active in the other phase. The approach introduced in this paper provides the rejection of the received message. In fact, in Figure 18, the amplitude (red line at the bottom) is just zero, so the lamp persists in its previous state (i.e. off). Considering that some nodes are not directly reachable by the Master, it is necessary to point out how the topology of the network also allows for messages to reach these nodes. This task, as mentioned previously, is assigned to the slave that can also act as a repeater. For instance, the message sent by the master to the slave controller with *ID = 038* is also received by the slave 031

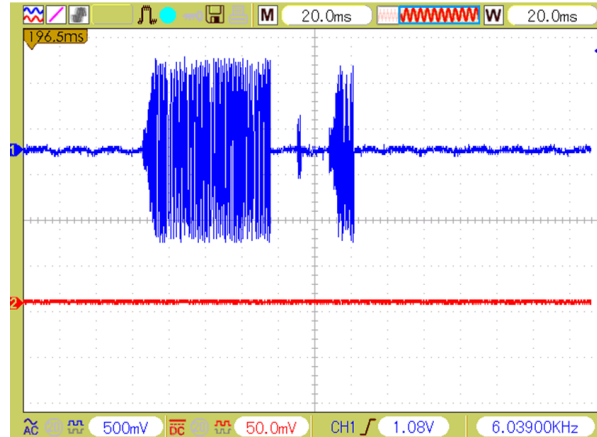

Figure 18: Cross coupling interference example.

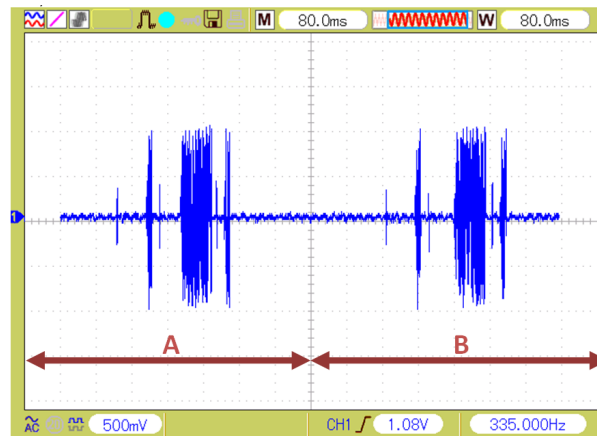

Figure 19: Routing example Transmission.

and is rebroadcast on the bus; this avoids the problem of the attenuation of the line up with the square of the distance. In Figure 19 the feature that a slave can also act as a repeater is shown. In detail, it receives the packet (section labeled as *A*) and forwards the same after having modified the recipient field (section labeled as *B*). This mechanism enables all nodes of the network to be able to implement the commands to their intended use. A common command actuated by the farthest slave is depicted in Figure 20; it is 650 meters away. Thanks to the solution introduced in this paper, which gives slaves the capability to act as a repeater, the receiver gets the frame and can perform the proper operation rightly. The lamp is on with duty cycle equal to 30%.

Finally, the obtained results regarding the energy consumption reductions, in the streets of Castellana, are shown. It is useful to note that the proposed method has been implemented and tested through the substitution of traditional 200W HPS lamps with those LED 80W. The results have been achieved taking into account the reduction of flow tables set up in the central host via the client side. In detail, the power consumption of the LED lamps without any control is depicted in Figure 21, while Figure 22 shows the energy consumption with lamp dimming through PLC communication. Thanks to the solution introduced in this paper, it is possible to obtain an energy saving of about 30% over the standard approach. Furthermore, Table 1 shows the flow rate reduction for the first day of February registered on the network implemented in Castellana.

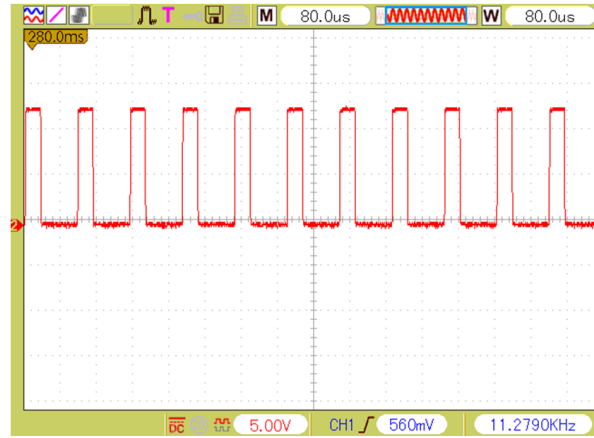

Figure 20: Implemented command.

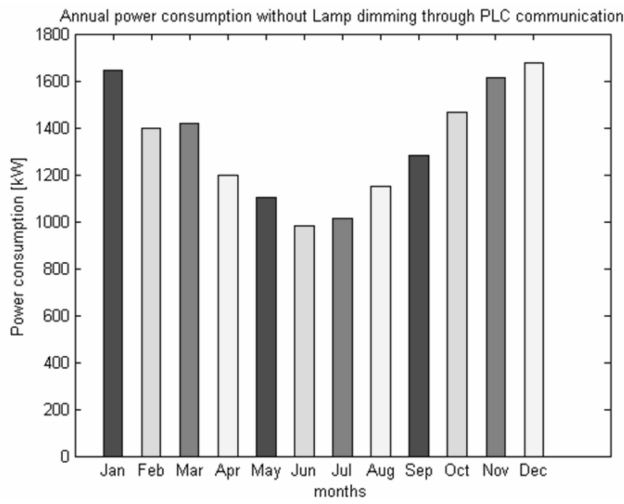

Figure 21: Power consumption without lamp dimming through PLC communication.

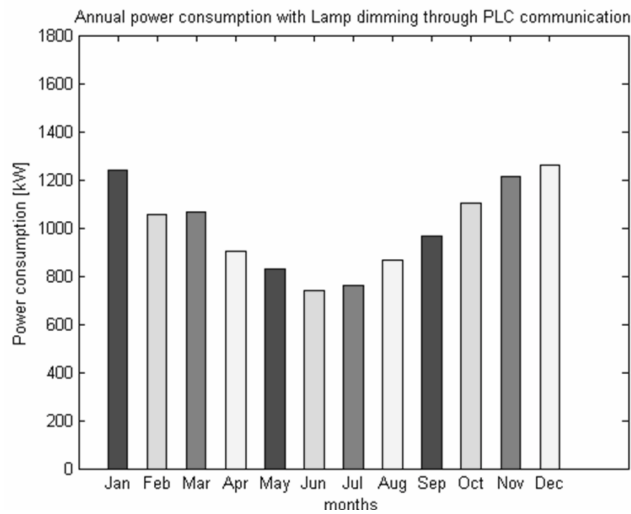

Figure 22: Power consumption with lamp dimming through PLC communication.

Table 1: Flow rates for time slot on February.

Antecedent (Start)	Antecedent (End)	Consequent (Flowlevel)
16:00	17:00	0
17:00	18:00	30
18:00	19:00	70
19:00	20:00	100
20:00	21:00	100
21:00	22:00	100
22:00	23:00	100
23:00	24:00	70
24:00	1:00	60
1:00	2:00	60
2:00	3:00	50
3:00	4:00	45
3:00	5:00	45
5:00	6:00	40
6:00	7:00	20
7:00	8:00	0

6 Conclusions

In this work, an innovative approach to deal with the problem of cross-coupling interference in street lighting networks has been presented. The proposed approach can face not only the problem of the capacitive coupling among the phases but also the attenuation that grows with the square of the distance. The approach introduced in this work can cope with these issues because every network node can operate as a repeater in information exchange. A first advantage in applying the proposed solution is that the measured delays, introduced to deliver messages to the farthest nodes of the Master Controller, are low. A further advantage is that if a device goes into fault, the Master can use alternative routes to reach the other slave nodes. As a consequence, the proposed network architecture, achieved through the design and creation of several ad-hoc devices, is fault tolerant. The paper has provided extensive assessments to validate the proposed solution. These experimental measures have been performed through the implementation of the proposed approach in Castellana, a small town in Sicily - Italy, regarding master/slave transmission, cross-coupling interference, routing and power consumption.

References

- [1] C. Chakraborty, H.-C. Iu, and D.-C. Lu, "Power converters, control, and energy management for distributed generation," *IEEE Transactions on Industrial Electronics*, vol. 62, no. 7, pp. 4466–4470, May 2015.
- [2] Y. Chen and Z. Liu, "Distributed intelligent city street lamp monitoring and control system based on wireless communication chip nrf401," in *Proc. of the International Conference on Networks Security, Wireless Communications and Trusted Computing (NSWCTC'09), Wuhan, Hubei, China.* IEEE, April 2009, pp. 278–281.
- [3] T.-J. Park and S.-H. Hong, "Experimental case study of a bacnet-based lighting control system," *IEEE Transactions on Automation Science and Engineering*, vol. 6, no. 2, pp. 322–333, February 2009.
- [4] R. Carli, M. Dotoli, and R. Pellegrino, "Ict and optimization for the energy management of smart cities: The street lighting decision panel," in *Proc. of the 20th International Conference on Emerging Technologies and Factory Automation (ETFA'15), Luxembourg, Luxembourg.* IEEE, September 2015, pp. 1–6.

- [5] M. Mahoor, T. A. Najafaabadi, and F. R. Salmasi, "A smart street lighting control system for optimization of energy consumption and lamp life," in *Proc. of the 22nd Iranian Conference on Electrical Engineering (ICEE'14), Tehran, Iran.* IEEE, May 2014, pp. 1290–1294.
- [6] N. Huerta-Medina, E. L. Corominas, P. J. Quintana, and M. R. Secades, "Smart control for smart grids: From lighting systems to grid side management," in *Proc. of the 13th International Conference on Power Electronics (CIEP'16), Guanajuato, Mexico.* IEEE, June 2016, pp. 104–109.
- [7] M. Zhunussova, M. Jaeger, and D. Adair, "Environmental impact of developing large buildings close to residential environments," in *Proc. of the International Conference on Sustainable Mobility Applications, Renewables and Technology (SMART'15), Kuwait City, Kuwait.* IEEE, November 2015, pp. 1–8.
- [8] K. Mohring, T. Myers, I. Atkinson, J. VanDerWal, and S. van der Valk, "Sensors in heat: A pilot study for high resolution urban sensing in an integrated streetlight platform," in *Proc. of the IEEE Tenth International Conference on Intelligent Sensors, Sensor Networks and Information Processing (ISSNIP'15), Singapore, Singapore.* IEEE, April 2015, pp. 1–6.
- [9] M. Bezbradica and Z. Trpovski, "Advanced street lighting maintenance using gps, light intensity measuring and incremental cost-effectiveness ratio," in *Proc. of the International Conference on High Performance Computing Simulation (HPCS), Bologna, Italy.* IEEE, July 2014, pp. 670–675.
- [10] Y. M. Yussoff and M. Samad, "Sensor node development for street lighting monitoring system," in *Proc. of the IEEE Symposium on Computer Applications Industrial Electronics (ISCAIE'16), Batu Feringghi, Malaysia.* IEEE, May 2016, pp. 26–29.
- [11] Z. Kaleem, I. Ahmad, and C. Lee, "Smart and energy efficient led street light control system using zigbee network," in *Proc. of the 12th International Conference on Frontiers of Information Technology (FIT'14), Islamabad, Pakistan.* IEEE, December 2014, pp. 361–365.
- [12] F. J. Nogueira, I. D. Melo, V. M. Albuquerque, L. H. Gouveia, C. G. Casagrande, D. P. Pinto, and H. A. C. Braga, "Street lighting led luminaires using telemanagement systems: Study of case," in *Proc. of the 11th IEEE/IAS International Conference on Industry Applications (INDUSCON'14), Juiz de Fora, Brazil.* IEEE, Dec 2014, pp. 1–8.
- [13] T. Ramachandran, L. T. Jung, V. Ponnusamy, and A. Hudaya, "Zigbee wireless communication for monitoring renewable street light system," in *Proc. of the International Conference on Computer and Information Sciences (ICCOINS'14), Kuala Lumpur, Malaysia.* IEEE, June 2014, pp. 1–6.
- [14] Electronic Industries Alliance, "Tia/eia-422," March 1998.
- [15] Institute of Electrical and Electronics Engineers, "802.15.4-2011 - ieee standard for local and metropolitan area networks, part 15.4: Low-rate wireless personal area networks (lr-wpans)," 2011, <https://standards.ieee.org/findstds/standard/802.15.4-2011.html>, [Online; Accessed on June 1, 2017].
- [16] Institute of Electrical and Electronics Engineers, "Ieee std. 802.11b-1999, wireless lan medium access control (mac) and physical layer (phy) specifications," 1999, <https://standards.ieee.org/findstds/standard/802.11b-1999.html>, [Online; Accessed on June 1, 2017].
- [17] D. Jimenez and F. Le Gall, "Testing a commercial sensor platform for wideband applications based on the 802.15.4 standard," *Journal of Wireless Mobile Networks, Ubiquitous Computing, and Dependable Applications*, vol. 6, no. 1, pp. 24–36, March 2015.
- [18] K. Szczypiorski and W. Mazurczyk, "Hiding data in ofdm symbols of ieee 802.11 networks," in *Proc. of the International Conference on Multimedia Information Networking and Security (MINES'10), Nanjing, Jiangsu, China.* IEEE, November 2010, pp. 835–840.
- [19] N. Pavlidou, A. Vinck, J. Yazdani, and B. Honary, "Power line communications: state of the art and future trends," *IEEE Communications Magazine*, vol. 41, no. 4, pp. 34–40, April 2003.
- [20] L. T. Berger, A. Schwager, P. Pagani, and D. M. Schneider, "Mimo power line communications," *IEEE Communications Surveys Tutorials*, vol. 17, no. 1, pp. 106–124, July 2015.
- [21] R. Morales, F. J. Badesa, N. García-Aracil, C. Perez-Vidal, and J. M. Sabater, "Distributed smart device for monitoring, control and management of electric loads in domotic environments," *Sensors*, vol. 12, no. 5, pp. 5212–5224, March 2012.
- [22] M. A. Mannah, C. Batard, N. Ginot, and M. Machmoun, "Power line communication over feeder cables in an industrial environment," in *Proc. of the IEEE International Symposium on Power Line Communications*

- and Its Applications (ISPLC'09), Dresden, Germany.* IEEE, March 2009, pp. 255–260.
- [23] X. Zhao, C. Jiang, Y. Wang, J. Yuan, and I. You, “Inter-cluster topology control: An evolutionary game perspective,” in *Proc. of the 7th International Conference on Innovative Mobile and Internet Services in Ubiquitous Computing (IMIS'13), Taichung, Taiwan.* IEEE, July 2013, pp. 76–82.
- [24] M. Collotta, L. Lo Bello, and O. Mirabella, “Deadline-aware scheduling policies for bluetooth networks in industrial communications,” in *Proc. of the International Symposium on Industrial Embedded Systems (SIES'07), Lisbon, Portugal.* IEEE, July 2007, pp. 156–163.
- [25] M. Collotta, S. Tirrito, and R. Caponetto, “Flexible street lamp lighting system management through power line,” in *Proc. of the International Symposium on Power Electronics, Electrical Drives, Automation and Motion (SPEEDAM'14), Ischia, Italy.* IEEE, June 2014, pp. 1021–1026.
- [26] S. Cho and V. Dhingra, “Street lighting control based on lonworks power line communication,” in *Proc. of the IEEE International Symposium on Power Line Communications and Its Applications (ISPLC'08), Jeju City, South Korea.* IEEE, April 2008, pp. 396–398.
- [27] M. Gotz, M. Rapp, and K. Dostert, “Power line channel characteristics and their effect on communication system design,” *IEEE Communications Magazine*, vol. 42, no. 4, pp. 78–86, April 2004.
- [28] W. D. Wynn and B. Ridge, “Patent: Power line communication systems,” 1997, <https://www.google.com/patents/US7307511>, [Online; Accessed on June 1, 2017].
- [29] R. Caponetto, G. Dongola, L. Fortuna, N. Riscica, and D. Zufacchi, “Power consumption reduction in a remote controlled street lighting system,” in *Proc. of the International Symposium on Power Electronics, Electrical Drives, Automation and Motion (SPEEDAM 2008), Ischia, Italy.* IEEE, June 2008, pp. 428–433.
- [30] J. Postel, “User Datagram Protocol,” IETF RFC 768, August 1980, <http://tools.ietf.org/html/rfc768>, [Online; Accessed on June 1, 2017].
- [31] SIMCom, “AT Command Manual,” 2011, <http://www.datasheet-pdf.com/datasheet-html/S/I/M/SIM908-SIMCom.pdf.html>, [Online; Accessed on June 1, 2017].

Author Biography



Giovanni Pau is a professor at Faculty of Engineering and Architecture, Kore University of Enna, Italy. Prof. Pau received his Bachelor degree in Telematic Engineering from University of Catania, Italy; and his Masters degree (cum Laude) in Telematic Engineering and PhD from Kore University of Enna, Italy. Prof. Pau has published more than 35 papers in journals and conferences and authored 1 book chapter. He serves as Associate Editor of several journals. Moreover, he serves/served as a leading Guest Editor in several special issues. He collaborates/collaborated with the organizing and technical program committees of several conferences in order to prepare conference activities and is serving as a reviewer of several international journals and conferences. His research interests include wireless sensor networks, soft computing techniques, internet of things, home automation and real-time systems.



Mario Collotta received his PhD in 2011 from Catania University, Italy, on the topic of factory automation networks. Since 2010 he has served as an Assistant Professor with tenure in the Faculty of Engineering and Architecture at the Kore University of Enna, Italy, and in 2011 he becomes a principal researcher and director of the Computer Engineering and Network Laboratory. His research interests concern the realization of strategies and innovative algorithms in order to ensure a flexible management of resources in real-time systems and networks. He is a member of the IEEE

and has published 2 book chapters, and over 60 refereed international journals and conference papers. He has served on several committees of distinguished journals and international IEEE conferences. He is currently an Associate Editor of some Elsevier and Springer journals. Dr Collotta has also served as a Guest Editor and Lead Guest Editor of several special sections and special issues focused on the study of real-time networks, systems and applications.



Salvatore Tirrito obtained his PhD in Technologies and Aeronautical Infrastructure Management at the University of Enna ‘Kore’ in 2016. He received his Bachelor degree in Electronic Engineering from Polytechnic of Turin in 2010 and then in 2012, his Master degree summa cum laude in Electronic Engineer from the Polytechnic of Turin discussing a thesis entitled “Numerical methods for the analysis of real-time signals electromyographic cardiac”. His research interest includes wireless sensor networks, road monitoring, street-lighting systems and real-time systems, with particular emphasis on Power Line, ZigBee, and WiFi topics. In each of these research fields, he has produced several publications in international conferences and journals.



Riccardo Caponetto was born in Catania (Italy) in 1966. He received the electronic engineering degree from the University of Catania in 1991 and the Ph.D. in electrical engineering in 1995. He worked, from 1994 to 2001, in STMicroelectronics as researcher. From 01/10/2001 until today, he works at University of Catania, Italy, D.I.E.E.I., as Assistant professor. His interests include: systems modelling and control, fractional order systems and oft computing techniques. Riccardo Caponetto is co-author of: 9 international patents, 6 books, 7 chapters in book 45 publications on international journals and 98 publications in international conferences.