

PAPER • OPEN ACCESS

Campaign of measurements to probe the good performance of the new array FARCOS for spectroscopy and correlations.

To cite this article: L. Acosta *et al* 2016 *J. Phys.: Conf. Ser.* **730** 012001

View the [article online](#) for updates and enhancements.

Related content

- [Integration of the GET electronics for the CHIMERA and FARCOS devices](#)
- [The Farcos project: Femtoscope Array for Correlations and Femtoscopy](#)
- [A labelling scheme for higher-dimensional simplex equations](#)

Recent citations

- [Nuclear neck-density determination at Fermi energy with CHIMERA detector](#)
A. Pagano *et al*
- [An overview of OSCAR: a new hodoscope of silicon detectors for low energy charged particles](#)
D. Dell'Aquila
- [Experimental investigation of condensation in light nuclei](#)
J. Bishop *et al*

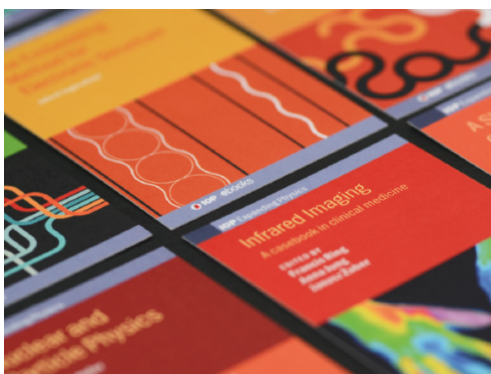

IOP | ebooks™

Bringing together innovative digital publishing with leading authors from the global scientific community.

Start exploring the collection—download the first chapter of every title for free.

Campaign of measurements to probe the good performance of the new array FARCOS for spectroscopy and correlations.

L. Acosta^{1,2,*}, R. Andolina³, L. Auditore⁴, C. Boiano⁵, G. Cardella², A. Castoldi^{5,6}, M. D'Andrea², E. De Filippo², S. De Luca⁴, D. Dell'Aquila⁷, L. Francalanza⁷, B. Gnoffo², C. Guazzoni^{5,6}, G. Lanzalone^{8,9}, I. Lombardo⁷, N. Martorana^{3,9}, T. Minniti⁴, S. Norella⁴, A. Pagano², E.V. Pagano^{3,9}, M. Papa², T. Parsani^{5,6}, S. Pirrone², G. Politi^{2,3}, F. Porto^{3,9}, L. Quattrocchi⁴, F. Rizzo^{3,9}, P. Russotto², G. Saccà², A. Trifirò⁴, M. Trimarchi⁴, G. Verde^{2,10}, M. Vigilante⁷ and P. Zambon^{5,6,11}

1 Instituto de Física, Universidad Nacional Autónoma de México, Cd.Mx., Mexico

2 INFN-Sezione di Catania, Catania, Italy

3 Dip. di Fisica e Astronomia, Università di Catania, Catania, Italy

4 Dip. di Scienze Matematiche e Informatiche, Scienze Fisiche e Scienze della Terra, Università di Messina & INFN Gruppo Collegato di Messina, Messina, Italy

5 INFN Sezione di Milano, Milano, Italy

6 Politecnico di Milano, Dip. di Elettronica, Informazione e Bioingegneria, Milano, Italy

7 INFN-Sezione di Napoli & Dip. di Fisica, Università di Napoli Federico II, Napoli, Italy

8 Università Kore Enna, Enna, Italy

9 INFN Laboratori Nazionali del Sud, Catania, Italy

10 Institute de Physique Nucléaire d'Orsay, Orsay, France

11 Dectris Ltd, Baden, Switzerland

E-mail: *acosta@fisica.unam.mx

Abstract.

During the last four years, several measurements have been carried out where the capabilities of FARCOS array were tested. In some of this occasions, FARCOS was coupled to the 4π array CHIMERA, permanently placed at INFN-Laboratori Nazionali del Sud, Catania in order to be tested in real experimental measurements. At the present situation, the FARCOS demonstrator is formed by 4 telescopes out of the originally 20 that will constitute the final array. Here are presented some preliminary results obtained with the new array, probing its qualities and showing the effectiveness of FARCOS telescopes. The initial encouraging results support the construction of the complete array.

1. Introduction

The FARCOS array (Fentoscope Array for Correlation and Spectroscopy) is a new detection system under construction. It is formed by telescopes composed of Double-Sided Silicon Strip Detectors (DSSSD) of 300 and 1500 μm thickness in the first and second stages respectively, and a third stage formed by four CsI(Tl) crystals of 60 mm thickness (see Fig. 1), having 132



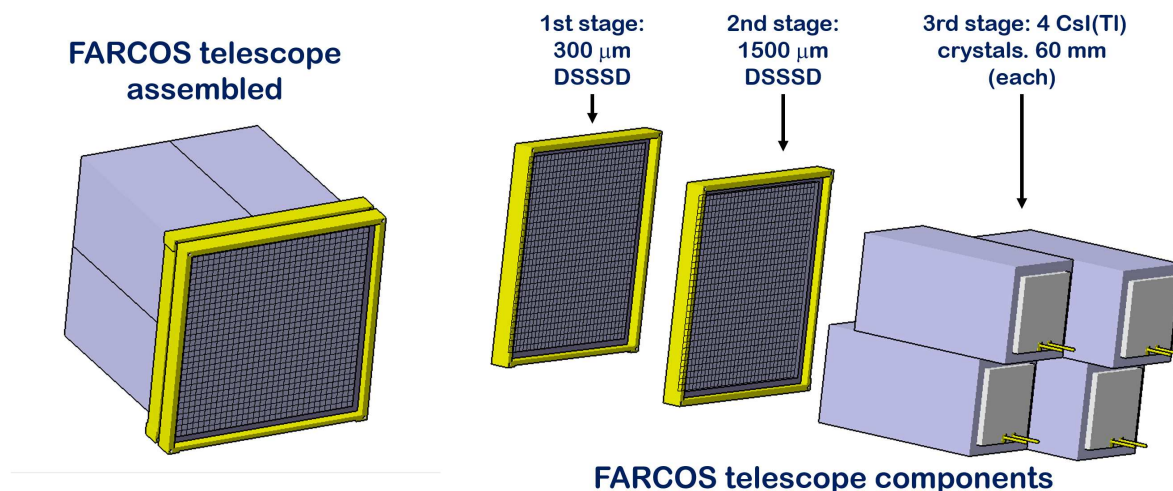

Figure 1. FARCOS telescope composition. Left image shows one of the FARCOS telescope assembled, while in the image on the right are show the components of each telescope: two DSSSD 300 and 1500 μm thickness respectively, and 4 CsI(Tl) crystals (60 mm each) at back, covering the same active area than the silicon detectors ($64 \times 64 \text{ mm}^2$).

detection channels in total by telescope. Presently the array (composed of 4 telescopes) is working as demonstrator of the final one, that will be formed by 20 telescopes.

The research program for FARCOS will be to study the particle-particle correlations at intermediate energies and spectroscopy of deep inelastic scattering for stable and radioactive nuclei reactions [1–4]. Moreover, considering the versatility of the array, FARCOS could be used for many other kind of studies.

In particle-particle correlation studies, good reconstruction of the relative energy depends on the angular and energy resolution of the detector. High energy resolution is also required in spectroscopy studies where it is very important to separate close-lying energy states. For this reason, several tests were done to estimate the performance of each identification stage of the FARCOS telescopes, with special attention to energy resolution. During the last 4 years, different array components have been tested, in order to probe the capabilities of the detectors, electronics and digitalization systems [5]. Moreover, FARCOS has been included as part of the set-up in four nuclear physics measurements. At such experiments, FARCOS was used as an auxiliary detector since it was still in the construction phase. In the following sections, some of the preliminary results achieved with the FARCOS demonstrator are shown. The positive results achieved so far, are promising enough to proceed with construction of the full FARCOS array.

2. Qualification of CsI(Tl) crystals.

The first test of the FARCOS components was related with the third stage of each telescope, composed by 4 CsI(Tl) crystals manufactured by Scionix [6] ($60 \times 32 \times 32 \text{ mm}^3$). The light collected on each crystal is detected by a Hamamatsu 18x18 mm PIN diode S3204-08. In order to test the crystal uniformity and resolution, a test with alpha beam (62A MeV) scattered by ^{208}Pb targets was carried out. Using a DSSSD in front of the crystals, it was possible to map the impact position over the crystal surface, achieving a good method to improve the resolution of the crystal. In Fig. 2 the pixelation of the crystal signal is presented, and how the energy

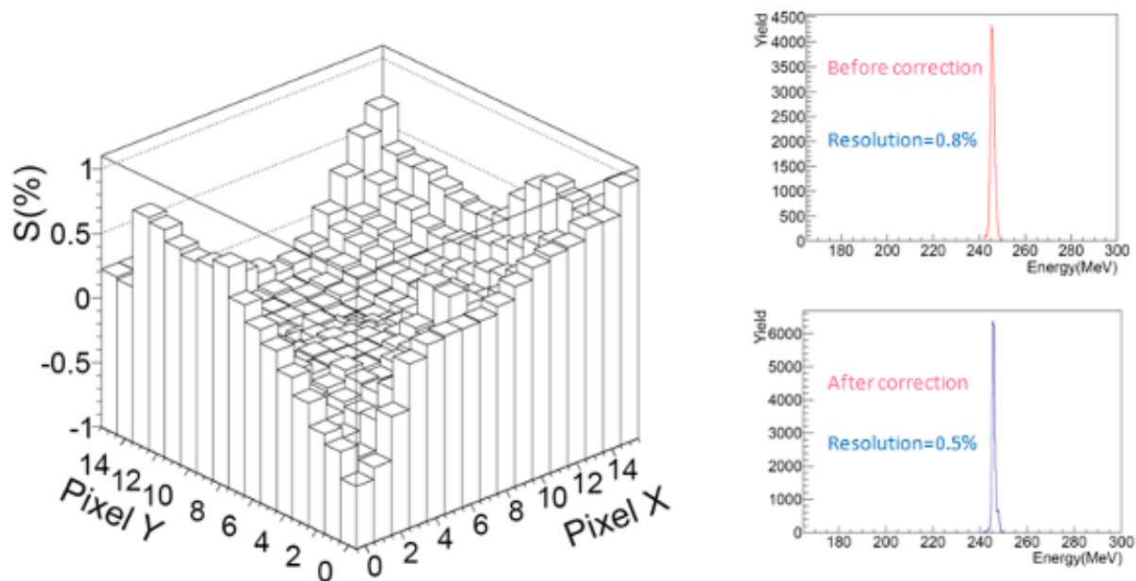

Figure 2. Light response for one CsI(Tl) crystals of FARCOS (left) and energy spectrum before and after correcting for the light response of each pixel with respect to the average response over the entire crystal (right). (Taken from [7]).

signal can be corrected for light response non-uniformities in the crystal. As is shown in Fig. 2 (right side) the energy resolution of CsI(Tl) spectra improve from 0.8% to 0.5%, after taking into account the light response of each pixel with respect to the average response of the crystal. More details of this test of crystals can be found in [7].

In order to test the CsI(Tl) crystals resolution, a standard Charge Sensitive Pre-amplifier (PAC) was used, with gain of 90 mV/MeV to process the signals with two different data acquisition systems: analogue acquisition with commercial 16-channel NIM Amplifiers and a VME QDC and digital acquisition of PAC signals with GET electronics [9]. In both cases the resolution reached was similar, around 3% FWHM, which is sufficient for FARCOS scientific goals. Fig. 3(a) shows, for instance, a triple alpha source spectrum obtained with the standard analogue acquisition system.

3. DSSSD characterization.

For the case of the DSSSD used for FARCOS, several tests have been performed during the last 4 years including resolution tests with analogue and digital electronics and inter-strip effects. The DSSSD's were manufactured by Micron Semiconductor [8], and each detector has 32 vertical strips on the front side and 32 horizontal strips on the rear side, with a total active area of $64 \times 64 \text{ mm}^2$, and resulting in 1024 pixels of 4 mm^2 . The signal for each strip is connected to a kapton cable ending with a 34 pin female connector.

For the case of analogue readout, different tests were carried out comparing commercial pre-amplifiers (Mesytec modules [10]) and a dedicated design (32 channels pre-amplifiers developed by INFN-Milano and Politecnico di Milano) [11]. For both configurations amplifiers from CAEN [12], that are currently used for the CHIMERA silicon detectors, were employed. For the analogue set-up, a resolution around 30 keV was achieved for both kinds of pre-amplifiers. Fig. 3(b) shows an example of a triple alpha spectrum for the analogue electronic chain. By using digitizers, the resolution can be improved as was demonstrated when the tests were carried out using SIS3301 [13] digitizing modules at the output of a Anti-Aliasing Amplifiers (AAA) [14].

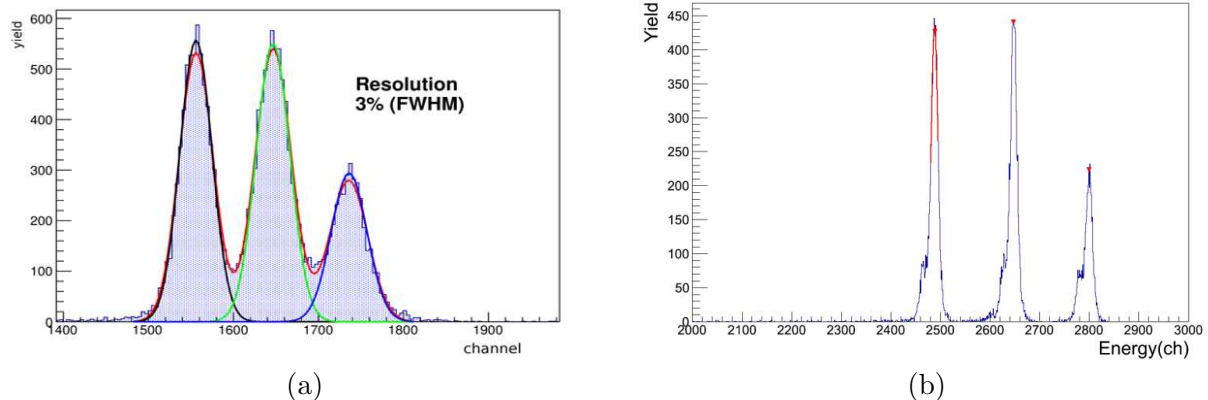

Figure 3. (a) Triple alpha spectrum for a FARCOS CsI(Tl) crystal by using analogical readout and standard DAQ, achieving a good resolution of 180 keV. (b) Triple alpha spectrum for a FARCOS 1500 μm DSSSD obtained with analogical electronics and standard DAQ. The resolution achieved is around 26 keV.

Using this electronic chain it was possible to reach a resolution around 15 keV for each strip on DSSSD's. The Fig. 4 shows the proton pulse beam calibration spectra taken from the data measured in the DEFEL-line at LABEC facility at Florence, Italy, during experiments dedicated to the study of inter-strip effects. A detailed description of these experiments can be consulted in [15].

4. Testing of FARCOS telescopes with nuclear reactions.

In order to test the capabilities of FARCOS demonstrator, it was mounted in four different measurements as part of the set-up of each experiment. These campaign of experiments was carried out during the last two years, in all of them the telescopes of FARCOS were placed in different geometries, according with the experiment needs. The studies to support each measurement will be described in further publications where a detailed description will be presented. Here we will show just some of the preliminary results achieved with FARCOS. The experi-

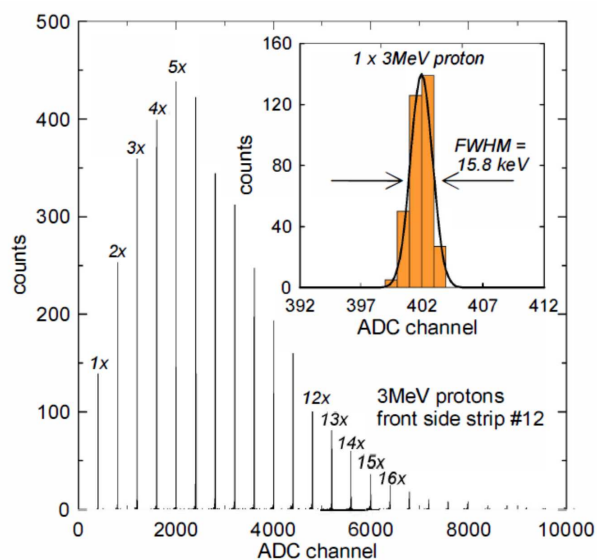

Figure 4. Energy spectrum collected in the case of 3 MeV proton interaction on one strip of the front side with a pulse beam from DEFEL line at LABEC, INFN-Florence. The number of ions in a bunch reflects their statistical distribution in the original beam; as a result, the spectrum envelope is roughly a poissonian distribution. The insets show a detail of the single proton peak together with its Gaussian fitting that allows extracting the peak centroid and FWHM. With this system, the resolution improves 50% with respect to the standard electronic chain (taken from [15]).

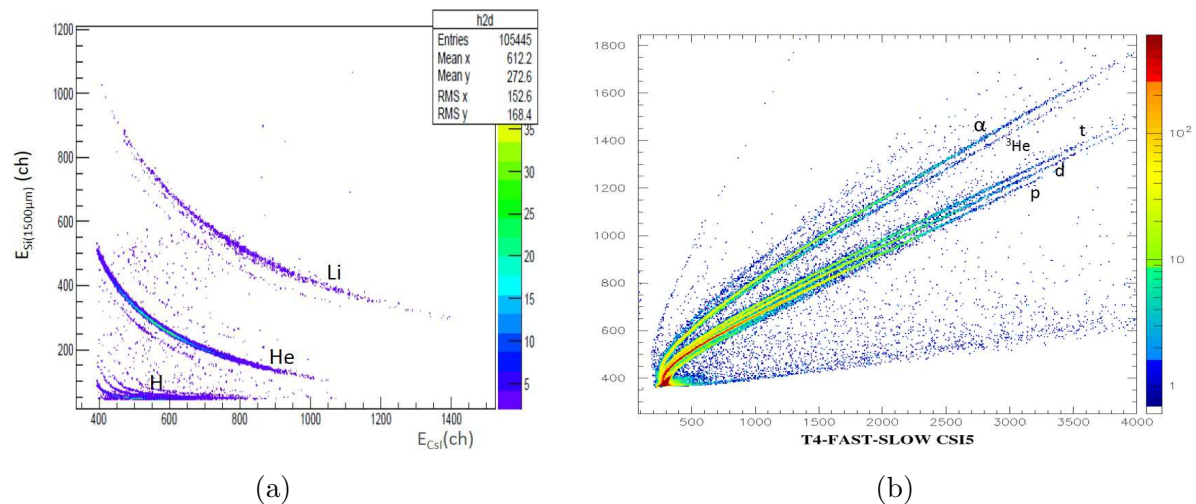

Figure 5. Preliminary spectra from INKIissy experiment data related with FARCOS demonstrator. (a) E- ΔE spectrum combining 1500 μm DSSSD (ΔE) and CsI(Tl) (E) signals. (b) Fast-Slow spectrum coming from the particles detected by CsI(Tl) crystals. Both spectra show the excellent resolution of a FARCOS telescope for mass and charge separation.

ments have the following labels: INKIissy [16–18], CLIR [19], SIKO [20] and PIGMY [21]. All of them were performed at Laboratori Nazionali del Sud, Catania, Italy, employing the CHIMERA multi-detector array [22] as the primary detection system. We present here some of the preliminary results related with FARCOS obtained during two of these measurements: INKIissy and PIGMY.

During the INKIissy experiment, many nuclei were produced coming from the $^{124}\text{Xe}+^{64}\text{Zn}$ reaction at 35A MeV. In this experiment, the FARCOS demonstrator was placed at $\theta_{Lab} = (20-40)^\circ$ from the reaction plane, covering a solid angle where typically 8 CHIMERA telescopes are mounted as part of the spherical detection configuration of the array. The preliminary results for particle identification using the FARCOS components are presented in Fig. 5a and b, where E- ΔE and Fast-Slow spectra are shown. For the particle identification spectrum using 1500 μm DSSSD and CsI(Tl) detectors, it is possible to see with an excellent energy resolution the isotopes corresponding to $^{1,2,3}\text{H}$, $^{3,4,6}\text{He}$ and $^{6,7}\text{Li}$; at the same time, using Fast-Slow technique with the CsI(Tl) crystals, p, d, t, ^3He and ^4He isotopes are as well clearly identified.

For the PIGMY experiment, FARCOS was placed close to $\theta_{Lab} \sim 0^\circ$, in order to have information about production of the ^{68}Ni nucleus from the fragmentation generated by the $^{70}\text{Zn}+^9\text{Be}$ reaction at 40A MeV. The spectrum in Fig. 6 shows the mass and charge separation using the E- ΔE technique. On the spectrum, masses 65, 67, 68, 69 and 71 can be easily identified, making possible the isolation of ^{68}Ni between many other species, which was part of the goals of the experiment.

5. Perspectives and conclusions.

We showed in the previous sections the very good performance of the FARCOS array. The performance assessment done so far open the way to the new development phase, taking place in the next two years.

During this next stage of development, dedicated very-large-scale integration (VLSI) charge

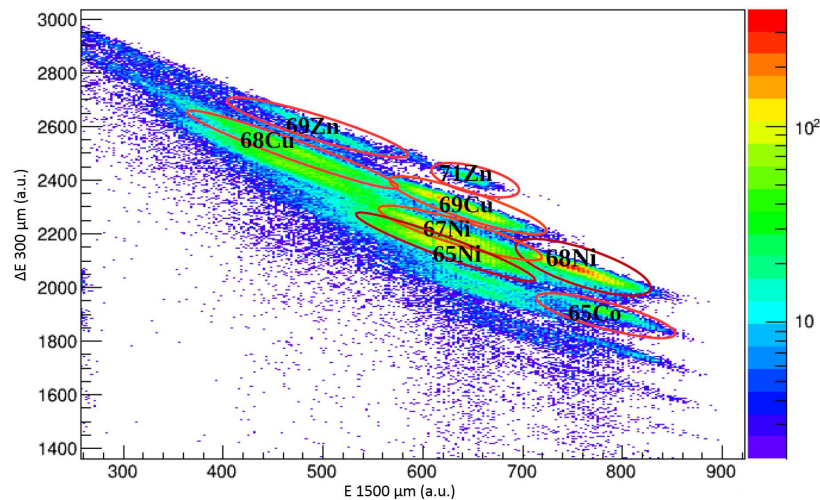

Figure 6. Energy spectra coming from data taken with FARCOS system at the PIGMY experiment. Mass and charge separation (^{68}Ni , for instance) can be easily observed by using the E- ΔE technique in silicon detectors. See the text for more details.

pre-amplifiers will be designed for the DSSSD and CsI(Tl) crystals. Considering the good resolution observed with digital data acquisition, the new electronics for the readout has been particularly designed to be compatible with this kind of system. The improved telescope will be equipped with an ASIC (for DSSSD and crystals) coupled to the telescope, in order to make a compact cluster, where just a few cables will control everything coming from the detectors (bias, test, signal and low-voltage). A preliminary design of the new telescope is shown in Fig. 7. Moreover, a complete mechanical system is under design, in order to hold the complete array (10 telescopes first, and 20 for the whole array). This new structure will be designed not just to hold a given geometry of the array, both also to stabilize the temperature of the system.

In conclusion, the FARCOS demonstrator has shown very good characteristics in position and energy resolution, even when used as a telescope. A variety of tests of electronic devices have resulted in digital electronics being chosen for the case of Silicon detectors. Several tests that have been carried out with FARCOS demonstrator have proven the very good performance presented by such a system. Even under realistic conditions, the FARCOS array

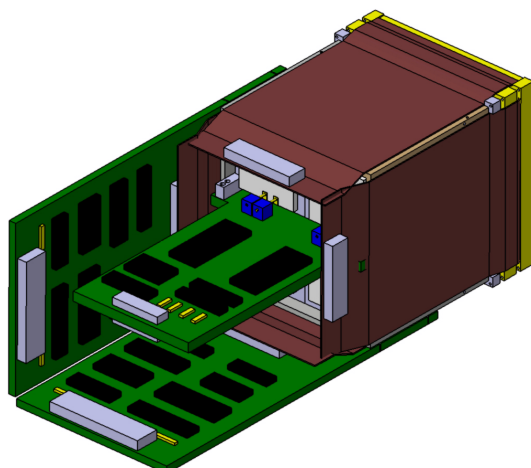

Figure 7. Rear view of the new design for a FARCOS telescope. Four dedicated ASIC boards will be mounted to the telescope (two are shown in the drawing), to manage the signals and bias voltages from DSSSD's, to which are connected by means of kapton cables. In the rear-middle, a single circuit will manage voltages and signals for four CsI(Tl) crystals.

has been a valuable plug-in supporting for the experiment and collecting data relevant for such measurements. During the coming years FARCOS will continue being used for further tests of new electronics and to support other measurements.

Acknowledgments

This work has been partially supported by UNAM-PAPIIT IA101616.

References

- [1] Verde G *et al.* 2006 *Eur. Phys. J. A* **30** 81
- [2] Acosta L *et al.* 2012 *Eur. Phys. J. Web of Conf.* **31** 00035
- [3] Verde G *et al.* 2013 *J. Phys. Conf. Ser.* **420** 012158
- [4] Pagano E V *et al.* 2015 *Eur. Phys. J. Web of Conf.* **88** 00013
- [5] FARCOS, Technical Design Report. NEWCHIM LNS-INFN 2015
<https://drive.google.com/file/d/0B5CgGWz8LpOOc3pGTWdOcDBoWFE/view?pref=2&pli=1>
- [6] <http://www.scionix.nl/>
- [7] Quattrocchi L *et al.* 2014 *Eur. Phys. J. Web of Conf.* **66** 11001
- [8] <http://www.micronsemiconductor.co.uk/>
- [9] Pollacco E *et al.* 2012 *Phys. Procedia* **37** 1799
- [10] <http://www.mesytec.com/>
- [11] Acosta L *et al.* 2012 *IEEE Nucl. Sci. Symp. Conf. Rec.* N20-6
- [12] <http://www.caen.it/>
- [13] SiSiOOI3100 - User Manual, Struck Innovative System GmbH. Hamburg, Germany, 2008
- [14] Boiano C, Guazzoni C, Guazzoni P, Zetta L, and Pagano A 2010 *IEEE Nucl. Sci. Symp. Conf. Rec.* 1389
- [15] Acosta L *et al.* 2012 *IEEE Nucl. Sci. Symp. Conf. Rec.* N14-217
- [16] Russotto P *et al.* 2014 *J. Phys. Conf. Ser.* **515** 012020
- [17] Quattrocchi L *et al.* 2015 *Eur. Phys. J. Web of Conf.* **88** 01014
- [18] De Filippo E *et al.* 2016 *Eur. Phys. J. Web of Conf.* in press
- [19] Dell'Aquila D *et al.* 2016 *Phys. Rev. C* **93** 024611
- [20] Verde G and Kokalova T 2012 PAC-LNS INFN
- [21] Cardella G *et al.* 2013 PAC-LNS INFN
- [22] Pagano A *et al.* 2004 *Nucl. Phys. A* **734** 504